



Project Name: _____	
Location: _____	
Item #: _____	Qty: _____
Model #: _____	
ASA #	SES #

- Models:**
- EDST27-8
 - EDST48-12
 - EDST60-16

- Stainless Steel exterior finish, NSF approved aluminum interior, Stainless steel floor
- CFC-Free polyurethane insulation - foamed in place.
- Oversized and balanced refrigeration system (R-134A)
- Forced air design underneath the pans to allow greater air flow to the products without drying them in the process
- 10" full length polycarbonate cutting board.
- Standard with 1/6th size pans, 4" deep / will accommodate 6" deep pans
- Holds 33° F – 41° F in the top rail and cabinet
- Self contained system, no plumbing required.
- Front breathing refrigeration system
- 36" working height
- Self closing doors stay open feature
- Adjustable heavy duty epoxy coated wire shelves
- 4" diameter swivel casters standard, front two with brakes

SALAD/ SANDWICH TABLES



EDST27- 8 shown above



EDST48- 12 shown above



Conforms to UL and NSF-7 standards

Model	Doors	Capacity (Cu. Ft)	Shelves	Amps	HP	Voltage	NEMA Plug	Cord Length	Cabinet Dimensions			Shipping	
									L	D	H	Wt.	Cubes
EDST27-8	1	8	1	5.1	1/3	115/60/1	5-15P	8' (2,439 mm)	27" (686 mm)	30" (762 mm)	36" (914 mm)	214 (97 kg)	33 (.94 m3)
EDST48-12	2	12	2	6.0	1/3	115/60/1	5-15P	8' (2,439 mm)	48" (1,219 mm)	30" (762 mm)	36" (914 mm)	305 (139 kg)	55 (1.56 m3)
EDST60-16	2	16	2	7.3	1/2	115/60/1	5-15P	8' (2,439 mm)	60" (1,524 mm)	30" (762 mm)	36" (914 mm)	370 (168 kg)	68 (1.93 m3)

STANDARD FEATURES

REFRIGERATION SYSTEM.

- Forced air holds product temperature at 33°F to 41°F (-5°C to 5°C) in food pans and cabinet interior. Complies with and listed under ANSI/NSF-7-19976.3.
- Refrigeration system with guided air flow provides uniform temperature in cabinet interior and food pan rail.
- Tube system uses environmentally friendly (CFC free) R134A refrigerant.

CABINET CONSTRUCTION

- Exterior: stainless steel front, top and cabinet ends. Matching galvanized steel back.
- Interior: NSF approved aluminum with stainless steel covered corners.
- Entire cabinet and solid doors are foamed-in-place using 2" high-density, CFC-free, polyurethane insulation.
- 4" (127mm) diameter stem swivel casters, front two with brakes. 36" (915mm) work surface height. Self contained system, no plumbing necessary.

DOORS

- One piece construction magnetic door gaskets, removable without tools for easy cleaning.
- Self closing doors with 120° stay open feature for convenient loading and unloading of products.

ELECTRICAL

- The unit is pre-wired with cord and plug set included.

WARRANTY
One year warranty on all parts
and additional 4 year warranty on
compressor parts

Edesa

12800 N.W. 38th Avenue
Miami, FL 33054-4525 USA
Toll Free: 1.877.693.3372
Ph: 305.477.1680
Fax: 305.779.0173
www.edesausa.com

PLAN VIEW

SPECIFICATIONS SUBJECT TO CHANGE WITHOUT NOTICE

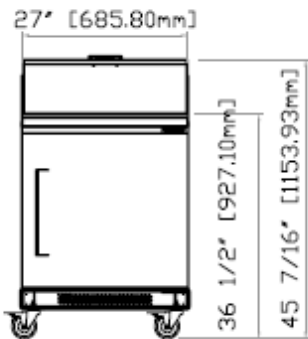

EDST-27 FRONT

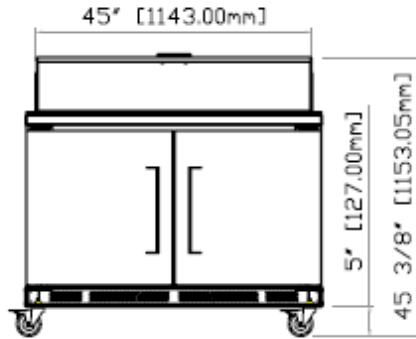

EDST-48 FRONT

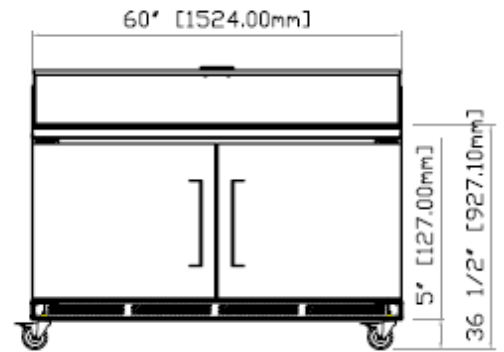

EDST-60 FRONT

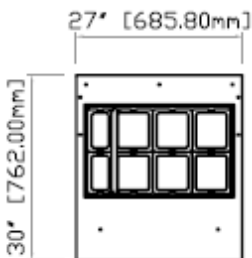

EDST-27 TOP

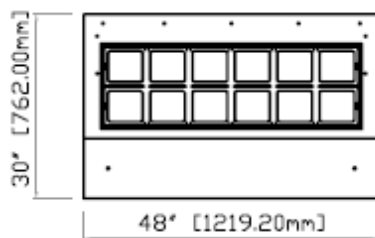

EDST-48 TOP

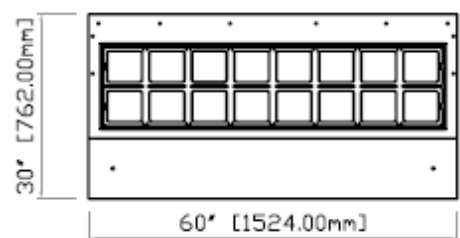

EDST-60 TOP