

Heater Proofer Non- Insulated

ITEM NO. _____

QUANTITY NO. _____

JOB NO. _____

SPEC NO. _____

100% Pre-Tested Electrical Assembly

Specifications:

- Heavy Duty, channel construction designed for durability.
Easy to Clean.
- Air baffle and circulating air blower provide even heat distribution.
- 5" polyurethane plate casters for easy maneuverability and stability.
- Two locking casters in front.
- Easy dual proof/heat control:
 - "Proof" mode: Humidity from 30% to 100%.
Temperatures up to 115°F (46°C)
 - "Heat" mode: Nominal Temperatures up to 185°F (85°C)
- Clear door. Extruded, anodized aluminum frame will not dull.
A tight fit gasket is installed on inside door frame, held closed with magnets,
Lexan fits tightly into door frame.
- Door lifts off for easy cleaning and accessibility.
- Control drawer is removable for quick and easy cleaning and maintenance.
- All controls are accessible without opening cabinet door.
- Easy to read LED thermometer.
- Pan Capacity: 35 - 18" x 26" pans

Electrical Specifications:

- 120 Volt-60 Cycle A.C.
- 1440 Watts: 14.0 AMPS - Plug into any standard 110 outlet.



NHPL-1836-ECO



NHP-PD-ECO
Removable Drawer
Makes Cleaning Quick & Easy

Laboratory Certification
and Approval Symbols:



141 Eileen Way • Syosset, NY 11791 • Tel: 1-800-444-3595 • Fax: 516-921-0538

www.winholt.com • sales@winholt.com

NEW YORK • PENNSYLVANIA • TEXAS • CALIFORNIA • MEXICO • CHINA

Heater Proofer Non-Insulated

ITEM NO. _____
 JOB NO. _____
 SPEC NO. _____

Heater Proofer Non-Insulated

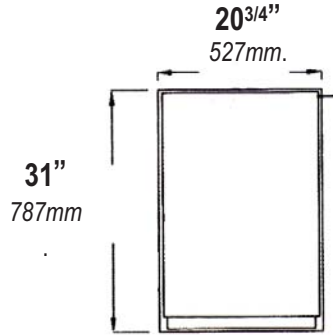

Top View

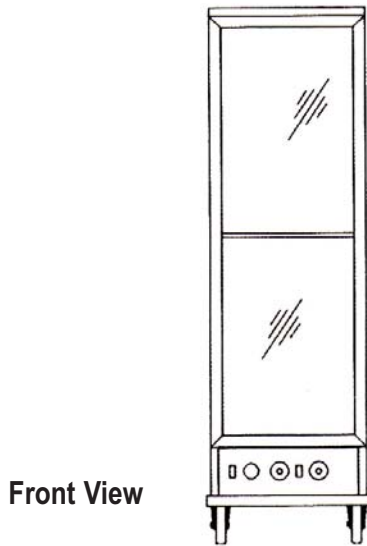

Front View

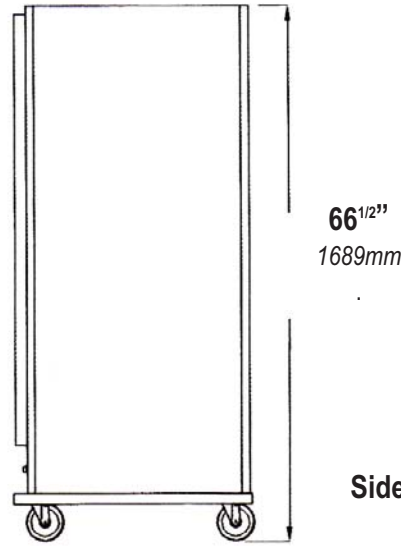

Side View

Model Number	Ordering Number	Feature	Overall Dimensions						Approx. Ship Weight	
			Width		Length		Height		(lb)	(kg)
			(in)	(mm)	(in)	(mm)	(in)	(mm)		
NHPL-1836-ECO	637795	Clear Door	20 ^{3/4}	527	31	787	66 ^{1/2}	1689	136	62
Replacement Caster Information										
738A	128784	Swivel Plate Caster with 5" Polyurethane Wheel							—	
738ABK	204185	Swivel Plate Caster with 5" Polyurethane Wheel & Brake							—	
7112	122180	5" Polyurethane Wheel							—	

Win-Holt Equipment is a leading manufacturer of material & food handling equipment. Since 1946, retailers and restaurant chains have trusted Win-Holt's equipment to ensure increased productivity and efficiency in their operation. Multiple locations reduce logistics and transportation costs. All Win-Holt associates are dedicated to customer satisfaction.

For general sales and engineering information only. All units are subject to change without notice. Please consult factory for certified specifications.

141 Eileen Way • Syosset, NY 11791 • Tel: 1-800-444-3595 • Fax: 516-921-0538

www.winholt.com • sales@winholt.com

NEW YORK • PENNSYLVANIA • TEXAS • CALIFORNIA • MEXICO • CHINA