

40 lb. (22 L.) Fryer



Fryer Features

- Stainless steel frypot, front, door, stub back and basket hanger.
- 40 lbs. (22 L.) stainless steel frypot with radius formed edges.
- Three high efficiency cast iron tube-fired burners provide a large heat transfer area for a fast recovery. Rated at 105,000 BTU/hr. (31 KW).
- Tubes are precision welded on the outside of the frypot for added durability. Welds are robotically welded for consistency.
- Unique baffle and deflectors inside the tubes diffuse heat to the tube wall to ensure even heat.
- Large "cool zone" captures food particles and keeps them from carbonizing in the fry zone.
- Millivolt temperature control circuit.
- Snap acting thermostat has a 200°F - 400°F (93°C - 204°C) temperature range.
- 100% safety shut-off valve.
- Two nickel-plated wire mesh fry baskets
- Fine mesh crumb screen.
- 1 1/4" (32) full port ball valve for quick draining.
- 6" (152) stainless steel legs with non-marking feet. Plate mounted for secure support.
- One year parts and labor warranty.
- AGA and CGA design certified, NSF and CE listed.



All measurements in () are metric equivalents.

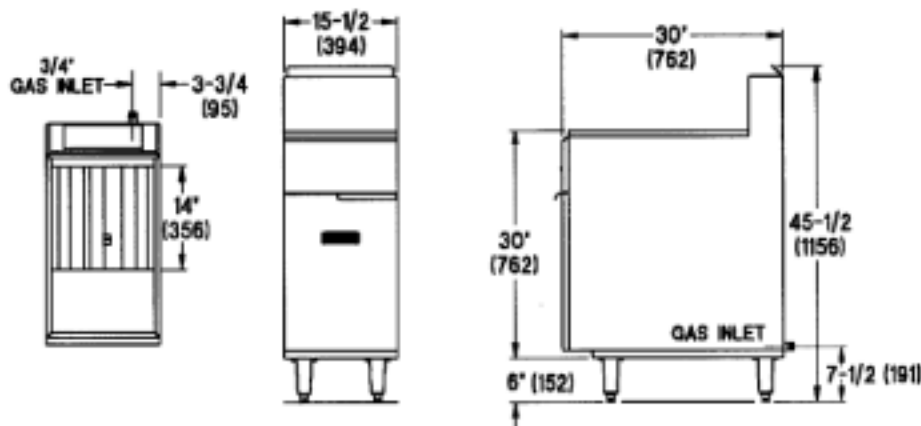

Model	Description	Oil Capacity Lbs.	(Liters)	Gas Output BTU	(KW)	Ship Weight (Kg.)	Lbs.
40 lb. Fryer	Stainless Steel Frypot	40	(22)	105,000	(31)	(100)	221

Crated Dimensions: 36" (891) d x 18" (461) w. Add 2" (51) to height of unit.

Gas

Manifold pressure is 4" W.C. for natural gas or 11" for propane gas. Manifold size 3/4" NPT. 3/8" pressure regulator supplied with equipment to be installed at time of connection. Specify type of gas and elevation if over 2,000 ft. (610 m).

Clearance

For use only on non-combustible floors. Legs or casters are required for non-combustible floors; or 2" (51) overhang is required when curb mounted. Provide 0" clearance from non-combustible surfaces and 6" (152) from combustible surfaces.

Imperial Commercial Cooking Equipment

1128 Sherborn Street ■ Corona, CA 92879 ■ 800.343.7790 ■ Ph: 951.281.1830 ■ Fx: 951.281.1879
www.imperialrange.com ■ E-mail: imperialsales@imperialrange.com