

# EVERPURE® QL3B SINGLE HEAD

FILTER HEAD EXCLUSIVELY FOR EVERPURE REPLACEMENT CARTRIDGES

QL3B Single Head: EV9259-24



## APPLICATIONS

Foodservice  
Vending  
OCS

## FEATURES • BENEFITS

Commercial quality filter head is designed exclusively to fit Everpure filter cartridges  
Includes built-in water shutoff valve  
Includes mounting bracket and screws  
All wetted parts have passed NSF® extraction tests  
Corrosion resistant hardware

Solid durable construction is ideal for foodservice and vending applications  
Engineered for durability, strength and longevity

## INSTALLATION TIPS

Mounts directly onto flat surface  
Install vertically so cartridge hangs down  
Allow 2-1/2" (6.35 cm) clearance below the cartridge for easy cartridge replacement  
Flush filter by running water through filter according to cartridge instructions

## OPERATION TIPS

Change cartridges on a regular six (6) month preventative maintenance program  
Change cartridges when capacity is reached or when pressure decreases  
Always flush the filter cartridge at time of installation and cartridge change

# EVERPURE® QL3B SINGLE HEAD

EV9259-24

## SPECIFICATIONS

### Overall Dimensions

3" H x 3.75" W x 3.5" D  
(7.6 x 9.5 x 8.9cm)

### Electrical Connection

None required

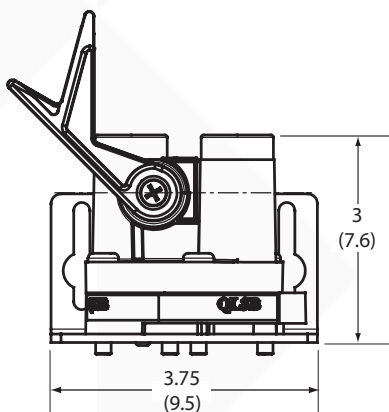

The contaminants or other substances removed or reduced by this drinking water system are not necessarily in your water. Do not use with water that is microbiologically unsafe or of unknown quality without adequate disinfection before or after the system. Systems certified for cyst reduction may be used with disinfected water that may contain filterable cysts.

## WARRANTY

Everpure Claris water treatment systems by Pentair® (excluding replaceable elements) are covered by a limited warranty against defects in material and workmanship for a period of one year after date of purchase. Everpure replaceable elements (filter cartridges and water treatment cartridges) are covered by a limited warranty against defects in material and workmanship for a period of one year after date of purchase. See printed warranty for details. Pentair will provide a copy of the warranty upon request.



### FILTRATION & PROCESSING SOLUTIONS

EVERPURE-SHURFLO WORLD HEADQUARTERS, 1040 MUIRFIELD DRIVE, HANOVER PARK, IL 60133 USA • WWW.EVERPURE.COM  
800.942.1153 MAIN (US ONLY) • 630.307.3000 MAIN • 630.307.3030 FAX • CSEVERPURE@PENTAIR.COM EMAIL

EVERPURE-SHURFLO AUSTRALIA / NEW ZEALAND, 1-21 MONASH DRIVE, DANDENONG SOUTH, VIC, 3175, AUSTRALIA  
1300.576.190 TEL • AU.EVERPURE@PENTAIR.COM EMAIL

EVERPURE-SHURFLO CHINA, 21F CLOUD 9 PLAZA, NO 1118, SHANGHAI, 200052, CHINA  
86.21.3211.4588 TEL • 86.21.3211.4580 FAX • CHINA.WATER@PENTAIR.COM EMAIL

EVERPURE-SHURFLO INDIA, GREEN BOULEVARD, B-9/A, 7TH FLOOR - TOWER B SECTOR 62, NOIDA - 201301  
91.120.419.9444 TEL • 91.120.419.9400 FAX • INDIACUSTOMER@PENTAIR.COM EMAIL

EVERPURE-SHURFLO EUROPE, PENTAIR WATER BELGIUM BVBA, INDUSTRIEPARK WOLFSTEE, TOEKOMSTLAAN, 30 B-2200 HERENTALS, BELGIUM  
+32.(0).14.283.500 TEL • +32.(0).14.283.505 FAX • SALES@EVERPURE-EUROPE.COM EMAIL

EVERPURE-SHURFLO JAPAN INC., HASHIMOTO MN BLDG. 7F, 3-25-1 HASHIMOTO, MIDORI-KU, SAGAMIHARA-SHI KANAGAWA 252-0143, JAPAN  
81.(0)42.775.3011 TEL • 81.(0)42.775.3015 FAX • INFO@EVERPURE.CO.JP EMAIL

EVERPURE-SHURFLO SOUTHEAST ASIA, 390 HAVELOCK ROAD, #04-01, KING'S CENTRE, SINGAPORE 169662  
65.6795.2213 TEL • FAX: 65.6795.2219 FAX • CSEVERPURE@PENTAIR.COM EMAIL

All Pentair trademarks and logos are owned by Pentair, Inc. All other brand or product names are trademarks or registered marks of their respective owners. Because we are continuously improving our products and services, Pentair reserves the right to change specifications without prior notice. Pentair is an equal opportunity employer.