

INSTRUCTION MANUAL

Full Size Gas Convection Oven

This manual contains important information regarding your unit. Please read this manual thoroughly prior to equipment set-up, operation and maintenance. Failure to comply with regular maintenance guidelines outlined in this manual may void the warranty.

WARNINGS

- Do not store or use gasoline or other flammable vapors or liquids in the vicinity of this or any other equipment
- Improper installation, adjustment, alteration, service or maintenance can cause property damage, injury or death
- Read the installation and maintenance instructions thoroughly before installing or servicing this equipment
- Have the equipment installed by a qualified installer in accordance with all federal, state and local codes
- Do not install or use without all 4 legs
- This equipment is for use in non-combustible locations only
- Do not obstruct the flow of combustion and ventilation air
- Do not spray controls or the outside of the equipment with liquids or cleaning agents
- Allow for hot parts to cool before cleaning or moving
- This equipment should only be used in a flat, level position
- Do not operate unattended
- Any loose dirt or metal particles that are allowed to enter the gas lines on this equipment will damage the valve and affect its operation
- If you smell gas, follow the instructions provided by the gas supplier. Do not touch any electrical switch; do not try to light the burner; do not use a telephone within close proximity.

TO INSTALL:

1. Remove unit from box and make sure all plastic, tape and packing materials are removed.
2. Place the unit on a flat, secure surface with at least 12" of open space around all sides.
3. Install the feet onto the unit and make sure the unit is level
4. Check to make sure the outlet of the correct voltage for this item (120V) and gas connection is near. Do not use an extension cord, this item must be plugged directly into an outlet.
5. Unit should be placed under a ventilation hood and there should be at least 2" of space between the back of the oven and the wall. This will ensure proper airflow

The installation of this equipment must conform with local codes, or with the National Gas Code, ANSIZ223.1/NFPA 54, or the Natural Gas and Propane Installation Code, CSA B149.1, as applicable.

The equipment and its individual shutoff valve must be disconnected from the gas supply piping system during any pressure testing of that system at test pressures in excess of ½ psi (3.5 kPa).

The equipment must be isolated from the gas supply piping system by closing its individual manual shutoff valve during any pressure testing of the gas supply piping system at test pressures equal to or less than ½ psi (3.5 kPa).

Clearance and positioning around the equipment:

This equipment must be installed adjacent to non-combustible surfaces only with a minimum spacing of 6" from all sides. This equipment must be a distance of 6" from other equipment. The equipment must have the legs installed and be placed on a non-combustible surface.

Air Supply and ventilation:

The area in front and around the equipment must be kept clear to avoid any obstruction of the flow of combustion and ventilation air.

Adequate clearance must be maintained at all times in front of and at the sides of the equipment for servicing and proper ventilation.

Pressure Regulator:

All commercial cooking equipment must have a pressure regulator on the incoming service line for safe and efficient operation. The regulator provided for this equipment is adaptable for both Natural gas and LP gas.

Regulator specifications: ¾" NPT inlet and outlet, factory adjusted for 4" WC Natural Gas standard and may be converted by qualified personnel to be used for Propane at 10" WC.

Gas Conversion:

Conversion from Natural Gas to Liquid Propane (LP) or vice versa may only be performed by the factory or its authorized service agent. In case of troubleshooting, ensure the correct orifice sizes of the tips have been provided.

Natural Gas Orifice is # 39

Liquid Propane Gas Orifice is #52

Orifice size is marked on the tip

Control Panel Features

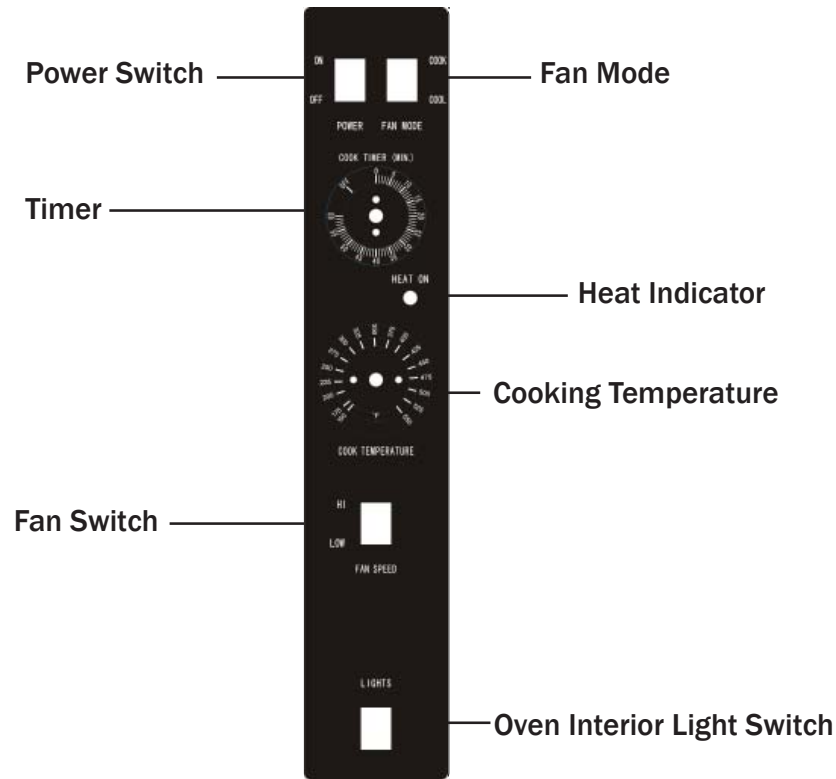

TO USE:

1. Turn the oven ON by using the power switch at the top of the control panel.
2. Select the desired fan speed using the fan speed switch
3. Switch the Fan Mode to Cook. In cook mode, the fan will run continuously when the oven doors are closed (The fan does not cycle on and off with the burners). If the switch is set to COOL, the fan will continue to run even with the doors open.
4. Set the cooking temperature by turning the Cook Temperature Control until the indicator mark on the knob is pointed to the desired cooking temperature. The HEAT ON indicator will light when the burners are on and will remain on while the oven pre-heats.
5. Wait until the HEAT ON indicator has turned on and off three times. After the third time, the oven will have reached the set cooking temperature.
6. Open the oven doors and load the product into the oven. Once product is set, close oven doors to start cooking
7. To set the Timer turn the Cook Timer until the indicator mark points to the desired cooking time. The timer goes from 0-55 minutes. A buzzer will go off once the timer hits 0. The buzzer will shut off after a little while. The timer does not control the oven. The timer will continue to run when the oven doors are open.
8. When the food is done cooking, you can quickly cool it down by opening the oven doors and switching the fan mode to either COOL or HI.
9. When you are done cooking, turn the oven off by turning the temperature to the lowest setting and switching the Power Switch to OFF.

CLEANING - NOTE: To maintain cleanliness and increase service life, this item should be cleaned daily. Do not immerse the unit in water or any other liquid, if liquid enters the electrical compartment it may cause a short circuit or electrical shock.

1. Before cleaning or attempting to move this item always turn off, unplug and let cool.
2. Wipe the entire unit with a clean soft cloth until it is completely dry.
3. To avoid damage to the unit, do not use abrasive cleaners or scouring pads.
4. If soap or chemical cleaners are used, be sure they are completely rinsed away with clean water immediately after cleaning. Chemical residue could damage or corrode the surfaces of the unit.

To avoid serious injury or damage, never attempt to repair or replace a damaged power cord yourself. Contact a professional repair service.

TROUBLESHOOTING

Problem	Possible Causes	Solution
No Heat	Ignitor defective	Call authorized Service center
No Heat	Power switch on control panel is off	Set the control panel to COOK
No Heat	Doors are open	Close doors
No Heat	Door micro switch defective	Call authorized service center
No Heat	Gas valve to oven may be in the cleared position	Turn gas valve on
Oven has not reached proper temperature	The oven has not reached pre-heat temperature	Wait for oven to reach pre-heat temperature
Oven has not reached proper temperature	Internal problem with main temperature control	Call authorized service center
Convection fan does not run	Oven has no electrical power	Check electrical supply
Convection fan does not run	Circuit breaker tripped	Reset the breaker
Convection fan does not run	Doors are open	Close doors
Convection fan does not run	Door Micro-switch defective	Call authorized service center

HELPFUL HINTS

Problem	Possible Causes	Solution
Food Browns unevenly	Improper heating temperature	Pre-heat until desired temperature is reached
Food Browns unevenly	Baking pan dark or glass	Lower oven temp by 25° F
Food dries before browning	Oven temp too high	Lower oven temp
Food dries before browning	Oven door opened too much	Stop opening oven door so much
Oven cycles 3 times and locks itself out	Flame sensor defective	Call authorized service center

Wiring Diagram for the Gas Convection Oven

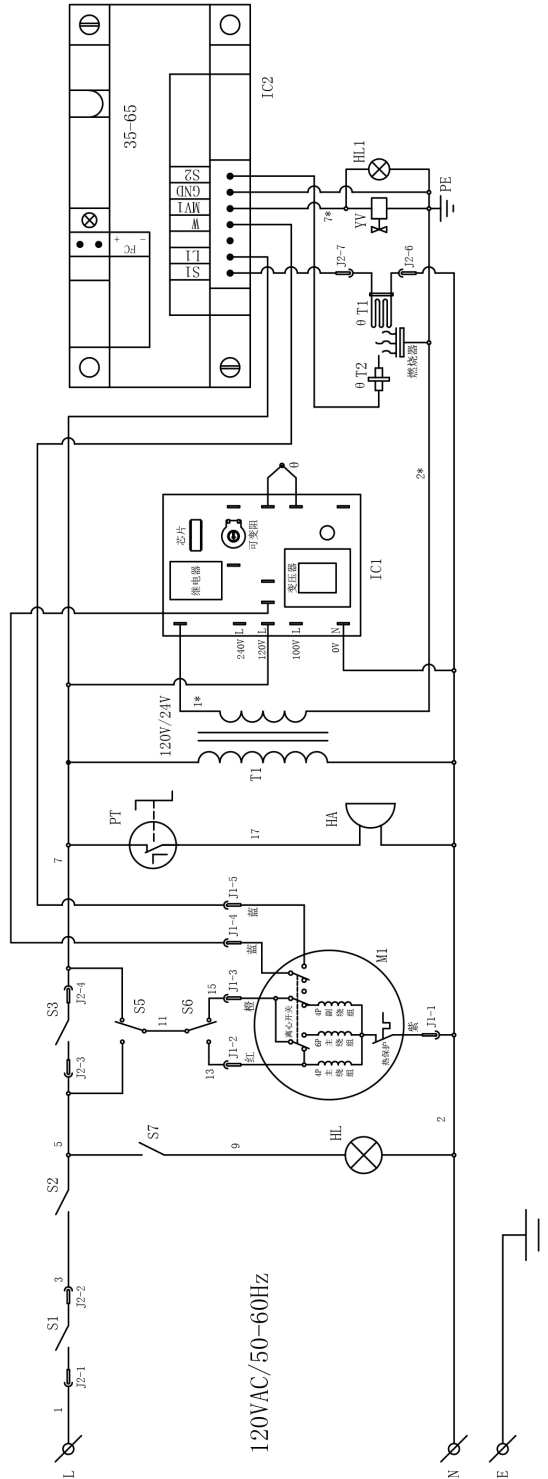

Parts Diagram for the Gas Convection Oven

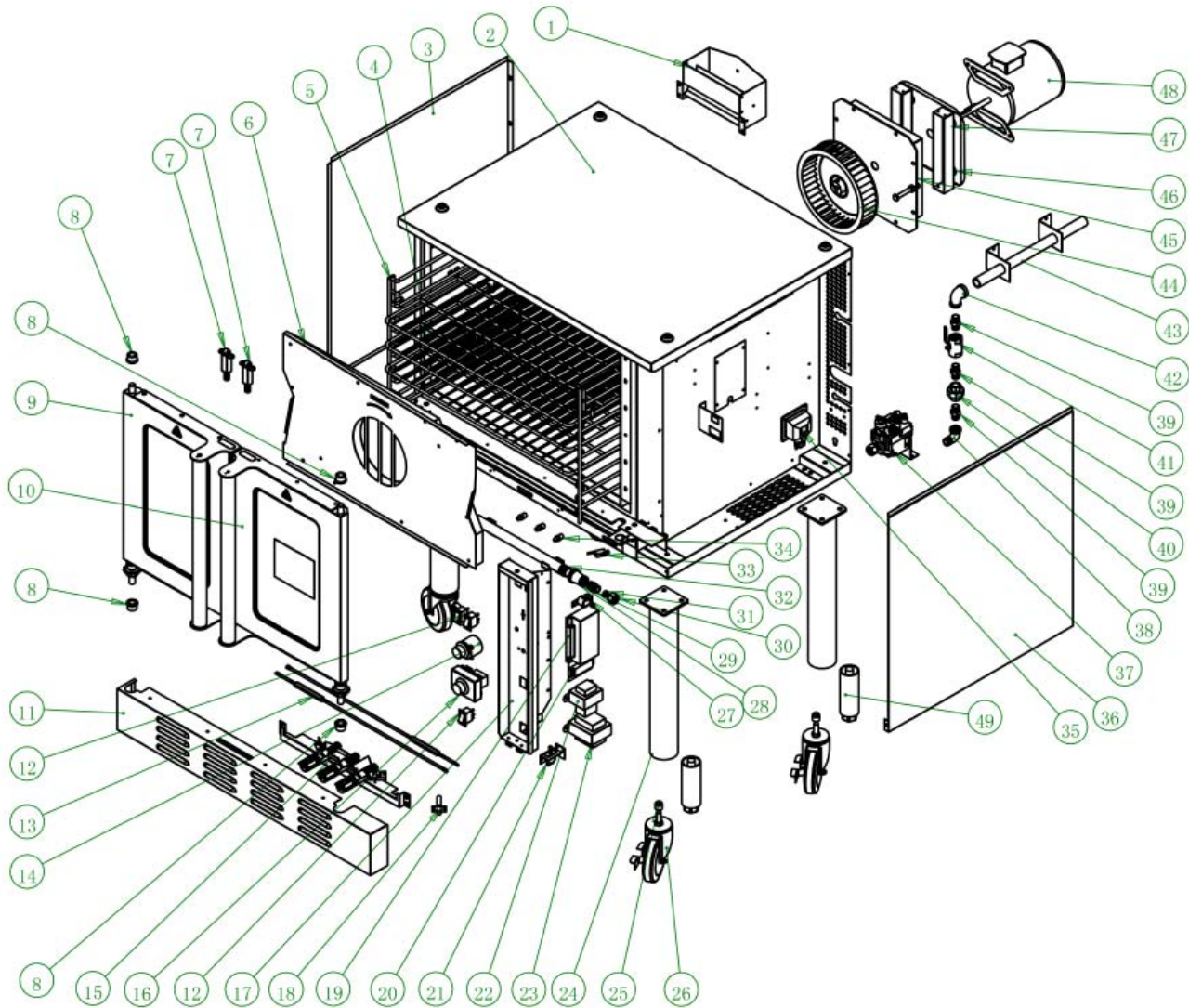

NO.	Description	QTY
1	REAR CHIMNEY	1
2	HOUSING ASSEMBLY UNIT	1
3	LEFT SIDE PANEL	1
4	RACK	5
5	RACK HOLDER	2
6	CONVECTION/HOT AIR COMPARTMENT ASSEMBLY	1
7	DOOR STOPPER ASSEMBLY	2
8	DOOR SHAFT BUSH	6
9	LEFT DOOR ASSEMBLY	1
10	RIGHT DOOR ASSEMBLY	1
11	LOWER FRONT COVER PLATE	1
12	WATER-PROOF SWITCH	3

Parts List for the Gas Convection Oven

NO.	Description	QTY
14	TIMER	1
15	BURNER ASSEMBLY	1
16	THERMOSTAT	1
17	CONTROL PANEL ASSEMBLY	1
18	HOT SURFACE IGNITER	1
19	IGNITION CONTROLLER	1
20	TERMINALS	1
21	TRAVEL SWITCH	2
23	TRANSFORMER	1
24	LEG ASSEMBLY	4
25	CONNECTOR	4
26	CASTER	4
27	BUZZER	1
28	STRAIGHT TUBE	1
29	CONNECTOR	2
30	NUT	2
31	HOOP	2
32	MANIFOLD	1
33	MICRO SWITCH	1
34	NOZZLE	3
35	BULB/LAMP HOLDER ASSEMBLY	1
36	RIGHT SIDE PANEL	1
37	SAFETY VALVE	1
38	ELBOW	1
39	STRAIGHT TUBE	3
40	UNION	1
41	BALL VALVE	1
42	ELBOW	1
43	GAS INLET PIPE	1
44	TURBO FAN	1
45	HEAT SHIELD ASSEMBLY	1
46	MOUNTING CONTOUR POST	4
47	INSULATION PAD	4
48	FAN	1
49	6in foot	4

WARRANTY

Patriot warrants its equipment against defects in materials and workmanship, subject to the following conditions:

Patriot gas equipment is warranted for three (3) years, effective from the date of purchase by the original owner. A copy of the original receipt or other proof of purchase is required to obtain warranty coverage. This warranty applies to the original owner only, and is not assignable.

The stainless steel fry tank has a five (5) year limited tank warranty. If during the first year, the tank is found to have a leak and is verified by an authorized service company, the entire fryer will be replaced. During years two through five, a new tank will be given.

Should any product fail to function in its intended manner under normal use within the limits defined in this warranty, at Patriot's discretion, such product will be repaired, replaced with a refurbished unit, or replaced with a new unit by Patriot, after defective unit has been inspected and defect has been confirmed. Patriot does not assume any liability for extended delays in replacing any item beyond its control. This warranty does not apply to rubber and non-metallic synthetic parts that may need to be replaced due to normal usage, wear or lack of preventative maintenance.

This warranty covers products shipped into the 48 contiguous United States, Hawaii, and metropolitan areas of Alaska and Canada. Warranty coverage on products used outside the 48 contiguous United States, Hawaii and metropolitan areas of Alaska and Canada may vary.

The following conditions are not covered by warranty:

- Equipment failure relating to improper installation, improper utility connection or supply and problems due to improper ventilation.
- Equipment that has not properly been maintained, damage from improper cleaning, and water damage to controls.
- Equipment that has not been used in an appropriate manner, or has been subject to misuse, neglect, abuse, accident, alteration, negligence, damage during transit, delivery or installation, fire, flood, riot, or act of God.
- Equipment that has the model number or serial number removed or altered.
- Equipment on which the security seal has been broken.

If the equipment has been changed, altered, modified, or repaired without express written permission from Patriot, then the manufacturer shall not be liable for any damages to any person or to any property, which may result from the use of this equipment thereafter.

This equipment is intended for commercial use only and this warranty is void if equipment is used in other than a commercial application.

For warranty and non-warranty related issues and technical support call NSA at 877-672-7740. Please have your model number, serial number and proof of purchase ready. It is not necessary to contact the place where you originally purchased your product from.

"THE FOREGOING WARRANTY IS IN LIEU OF ANY AND ALL WARRANTIES EXPRESSED OR IMPLIED INCLUDING ANY IMPLIED WARRANTY OF MERCHANTABILITY OR FITNESS FOR PARTICULAR PURPOSES AND CONSTITUTES THE ENTIRE LIABILITY OF PATRIOT. IN NO EVENT DOES THE LIMITED WARRANTY EXTEND BEYOND THE TERMS STATED HEREIN."

Please fill out and return the warranty registration card below to the address provided

WARRANTY REGISTRATION CARD

MAIL CARD
IMMEDIATELY



This card must be mailed immediately after installation date for warranty to be in effect.

National Service America • 230 Park Ave, Suite 1000 • New York, NY • 10169

(Name of Business) (Dealer Purchased From)

(Address) (City) (State) (Zip Code)

(Model Number) (Serial Number)

This is to inform that I, _____
(Please print name of individual who owns business)

have had the above installed in my place of business _____
(Date of Purchase)

(Contact Phone Number) (Contact E-mail) (Signature of individual who owns Business)

The above warranties are in effect from this installation date, or 90 days, which ever comes first.