

Designer Series Electric Fryer

Project _____
Item _____
Quantity _____
CSI Section 11400
Approved _____
Date _____

Models

- ED-15F • EDU-18F • ED-30FT
- ED-15SF • EDU-18SF • ED-30SFT



Model ED-15SF

Standard Features

- Stainless steel front and sides
- Removable stainless steel tank, 17Lb (7.7Kg) capacity
- Set of twin fryer baskets
- Easy clean design with recessed protected controls.
- Heat-On indicator lamps
- 5300 watts per frypot
- Super fryer with 8000 watts per frypot, has suffix SF or SFT
- Models with EDU prefix are "CE" approved
- One-Year limited parts & labor warranty (USA & Canada only)

Options & Accessories

- Stainless steel back and bottom
- Stainless steel bowl cover, one required per frypot
- Stainless steel fryer fish plate
- One large fryer basket in lieu of twin set of baskets

Note: Stands are available see form # CS24/CSD

Specifications

Electric designer series fryers in two size groups: Single tank models; 15" (381mm) wide ED-15F/SF, or 18" (457mm) wide EDU-18F/SF (CE approved); and twin tank models 30" (782mm) wide ED-30FT/SFT. Designed as free standing or to be banked with other ED series equipment. 24" (610mm) deep x 13" (330mm) high with stainless steel front and sides, and stainless steel tank. Electronic thermostat provides concise accurate control. Removable flat bottom stainless steel tank with large surge. Twin tank model has two sets of independent controls. 5300 watts per frypot, super fryer available with 8000 watts per frypot; models with suffix SF or SFT. Models with prefix EDU are "CE" approved.

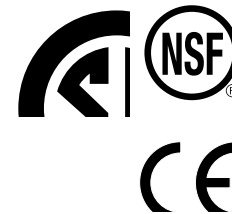

Designer Series Electric Fryer

Designer Series Electric Fryer

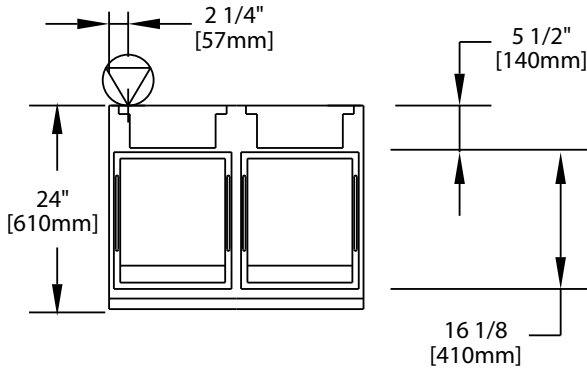

Garland products are not approved or authorized for home or residential use, but are intended for commercial applications only. Garland will not provide service, warranty, maintenance or support of any kind other than in commercial applications.

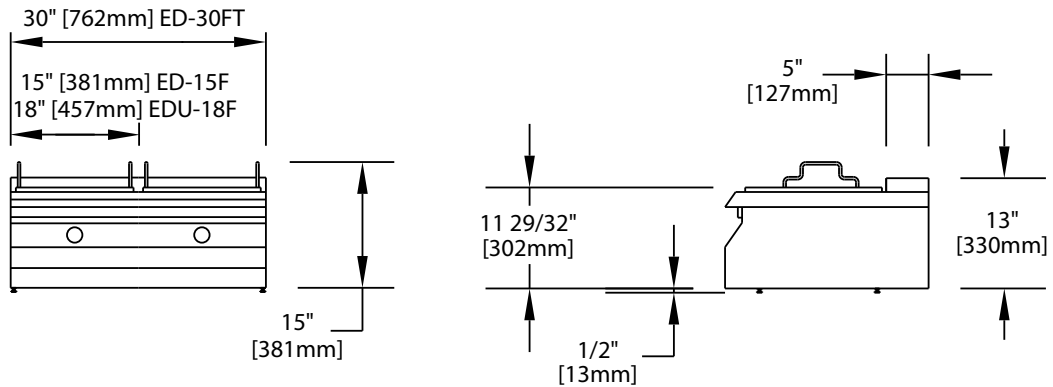

| Models | Total kW Load | | | | Nominal Amperes Per Line | | | | | | | |
|-------------------|---------------|---------------|---------------|------|--------------------------|------|------------------|---------------|---------------|---------------|-------------------------|-----|
| | | | | | North America | | | | Export | | | |
| | North America | | Export | | Single Phase | | Hi Line -3 Phase | | Single Phase | | Hi Line - 2 or -3 Phase | |
| 208V | 240V | 220V/ 380V | 240V/ 415V | 208V | 240V | 208V | 240V | 220V/ 380V | 240V/ 415V | 220V/ 380V | 240V/ 415V | |
| ED-15F, EDU-18F | 5.3 | 5.3 | 5.93 | 5.3 | 26 | 23 | N/A | N/A | 27 | 23 | N/A | N/A |
| ED-15SF, EDU-18SF | 8 | 8 | 8 | 8 | 39 | 34 | 23 | 20 | 37 | 34 | 13 | 12 |
| ED-30FT | 10.6 | 10.6 | 11.86 | 10.3 | 51 | 45 | 45 | 39 | 54 | 45 | 27 | 22 |
| ED-30SFT | 16.0 | 16.0 | 16.0 | 16.0 | 77 | 67 | 45 | 39 | 73 | 67 | 25 | 23 |

| Model | Overall Dimensions | | | Cu. Ft. | Shipping Wt. Lb/kg |
|-------------------|--------------------|-------------|-------------|---------|--------------------|
| | Height | Width | Depth | | |
| ED-15F, ED-15SF | 13" (330mm) | 15" (381mm) | 24" (610mm) | 5 | 50/23 |
| EDU-18F, EDU-18SF | 13" (330mm) | 18" (457mm) | 24" (610mm) | 5 | 50/23 |
| ED-30FT, ED-30SFT | 13" (330mm) | 30" (762mm) | 24" (610mm) | 10 | 70/32 |

| Installation Clearances | |
|-------------------------|-------------|
| Side | Rear |
| 0.5" (13mm) | 0.5" (13mm) |

Welbilt reserves the right to make changes to the design or specifications without prior notice.