

Model Number

IFSCB175E	IFSCB175EU
IFSCB275E	IFSCB275EU
IFSCB375E	IFSCB375EU
IFSCB475E	IFSCB475EU
IFSCB575E	IFSCB575EU
IFSCB675E	IFSCB675EU

Add suffix "T" for Electronic Thermostat

Add suffix "C" for Computer Controls

Suffix "E" denotes Immersed Elements

Suffix "EU" denotes Tilt-up Elements

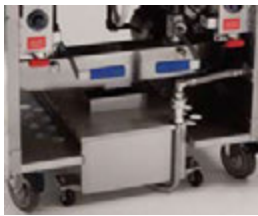

Filter is located under fryers to save valuable space.



Filter pan is designed for maximum oil return.



5.5 GPM, 1/3 HP roller pump speeds up filtering process.



Side Car includes a stainless steel cabinet with a drain area, food warmer and dump pan.



FILTER PACKAGE CHOICES - Up to six fryers can be battered into one fryer / filter system.

- Available for 50 and 75 lb. (27 and 41 Liters) oil capacity fryers.
- Available with Snap Action Thermostats, Electronic Thermostats or Computer Controls

LOCATED UNDER FRYERS - Filter location under fryers saves valuable space.

- Internally plumbed oil drain and return line.

UNIQUE FILTER PAN DESIGN - Filter pan is designed for maximum oil return.

- Stainless steel construction is easy to clean and has a professional look.
- Positive-latching filter paper holder holds paper in place for optimal filtration.
- Quick disconnect connection offers quick and safe connection of the filtered oil back into the frypots.
- All oil drain and return lines are internally plumbed for convenience and safety.

ROLLER-PUMP - Up to six fryers can be battered into one fryer / filter system.

- 5.5 GPM pump with a 1/3 HP motor speeds up filtering process.
- Can pump oil into a disposal vat up to 20 feet away.

DRAIN STATION - Includes a matching stainless steel cabinet with a food warmer and dump pan.

- Cabinet may be located anywhere within the fryer battery.
- Cabinet is a convenient storage area when located at the end of the battery.

EXTERIOR FEATURES - Continuous cabinet provides a professional look.

- 5" (127 mm) deep continuous stainless steel front landing ledge.
- Stainless steel precision welded frypot.
- Includes casters, joiner strips and filter starter kit.



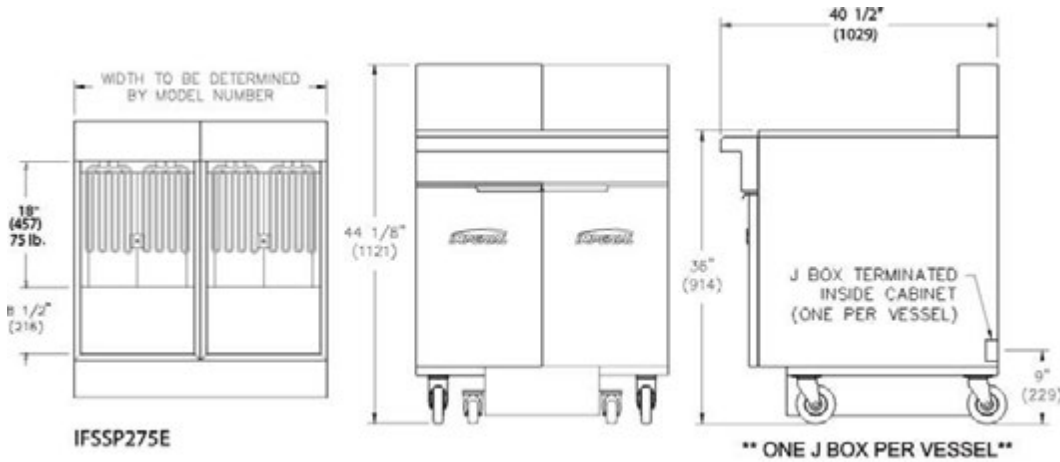

MODEL	FRYER OIL CAPACITY	OVERALL WIDTH	NUMBER OF FRYERS	SHIP WEIGHT (KG)	LBS
IFSCB175E	75 lbs. (51 L)	39" (911 mm)	1	(217)	480
IFSCB275E	75 lbs. (51 L)	58-1/2" (1486 mm)	2	(327)	720
IFSCB375E	75 lbs. (51 L)	78" (1981 mm)	3	(449)	990
IFSCB475E	75 lbs. (51 L)	97-1/2" (2477 mm)	4	(572)	1260
IFSCB575E	75 lbs. (51 L)	117" (2972 mm)	5	(694)	1530
IFSCB675E	75 lbs. (51 L)	136-1/2" (3467 mm)	6	(816)	1800

Measurements in () are metric equivalents.

MODEL	DIMENSIONS	CRATED DIMENSIONS
IFSCB175E	39" w x 40-1/2" d x 44-1/8" h (911 x 1029 x 1121 mm)	40-1/2" w x 43" d x 49-1/2" h (1029 x 1092 x 1257 mm)
IFSCB275E	58-1/2" w x 40-1/2" d x 44-1/8" h (1486 x 1029 x 1121 mm)	60" w x 43" d x 49-1/2" h (1524 x 1092 x 1257 mm)
IFSCB375E	78" w x 40-1/2" d x 44-1/8" h (1981 x 1029 x 1121 mm)	79-1/2" w x 43" d x 49-1/2" h (2019 x 1092 x 1257 mm)
IFSCB475E	97-1/2" w x 40-1/2" d x 44-1/8" h (2477 x 1029 x 1121 mm)	99" w x 43" d x 49-1/2" h (2515 x 1092 x 1257 mm)
IFSCB575E	117" w x 40-1/2" d x 44-1/8" h (2972 x 1029 x 1121 mm)	118-1/2" w x 43" d x 49-1/2" h (3010 x 1092 x 1257 mm)
IFSCB675E	136-1/2" w x 40-1/2" d x 44-1/8" h (3467 x 1029 x 1121 mm)	138" w x 43" d x 49-1/2" h (3505 x 1092 x 1257 mm)

FILTER ELECTRICAL REQUIREMENT			
VOLTS	PHASE	HERTZ	AMPS
115 V	1	60	6.8 amps

ELECTRICAL REQUIREMENT PER FRYER				
MODEL	VOLTS	PHASE	HERTZ	AMPS
75 lbs.	208	3	60	50.02
75 lbs.	240	3	60	43.35
75 lbs.	480	3	60	21.68

* For export only

CLEARANCE REQUIREMENTS

For use only on non-combustible floors. Legs or casters are required for non-combustible floors. Provide 0" clearance from non-combustible surfaces and 6" (152 mm) from combustible surfaces.

OPTIONS AND ACCESSORIES

- Automatic basket lifts with computerized controls
- Manual controlled basket lifts
- Stainless steel tank cover
- Stainless steel side drain shelf
- Stainless steel side splash
- Manual timer
- Filter paper 40# thickness, 20 microns, 100 sheets per box

