

EVERPURE® QL3B SINGLE HEAD

FILTER HEAD EXCLUSIVELY FOR EVERPURE REPLACEMENT CARTRIDGES

QL3B Single Head: EV9259-24



APPLICATIONS

Foodservice
Vending
OCS

FEATURES • BENEFITS

Commercial quality filter head is designed exclusively to fit Everpure filter cartridges

Includes built-in water shutoff valve

Includes mounting bracket and screws

All wetted parts have passed NSF® extraction tests

Corrosion resistant hardware

Solid durable construction is ideal for foodservice and vending applications

Engineered for durability, strength and longevity

INSTALLATION TIPS

Mounts directly onto flat surface

Install vertically so cartridge hangs down

Allow 2-1/2" (6.35 cm) clearance below the cartridge for easy cartridge replacement

Flush filter by running water through filter according to cartridge instructions

OPERATION TIPS

Change cartridges on a regular six (6) month preventative maintenance program

Change cartridges when capacity is reached or when pressure decreases

Always flush the filter cartridge at time of installation and cartridge change

EVERPURE® QL3B SINGLE HEAD

EV9259-24

SPECIFICATIONS

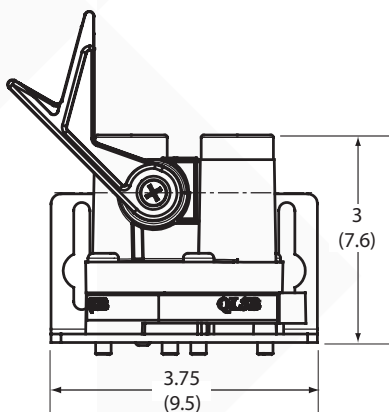

Overall Dimensions

3" H x 3.75" W x 3.5" D
(7.6 x 9.5 x 8.9cm)

Electrical Connection

None required

The contaminants or other substances removed or reduced by this drinking water system are not necessarily in your water. Do not use with water that is microbiologically unsafe or of unknown quality without adequate disinfection before or after the system. Systems certified for cyst reduction may be used with disinfected water that may contain filterable cysts.

WARRANTY

Everpure Claris water treatment systems by Pentair® (excluding replaceable elements) are covered by a limited warranty against defects in material and workmanship for a period of one year after date of purchase. Everpure replaceable elements (filter cartridges and water treatment cartridges) are covered by a limited warranty against defects in material and workmanship for a period of one year after date of purchase. See printed warranty for details. Pentair will provide a copy of the warranty upon request.



FILTRATION & PROCESSING SOLUTIONS

EVERPURE-SHURFLO WORLD HEADQUARTERS, 1040 MUIRFIELD DRIVE, HANOVER PARK, IL 60133 USA • WWW.EVERPURE.COM
800.942.1153 MAIN (US ONLY) • 630.307.3000 MAIN • 630.307.3030 FAX • CSEVERPURE@PENTAIR.COM EMAIL

EVERPURE-SHURFLO AUSTRALIA / NEW ZEALAND, 1-21 MONASH DRIVE, DANDENONG SOUTH, VIC, 3175, AUSTRALIA
1300.576.190 TEL • AU.EVERPURE@PENTAIR.COM EMAIL

EVERPURE-SHURFLO CHINA, 21F CLOUD 9 PLAZA, NO 1118, SHANGHAI, 200052, CHINA
86.21.3211.4588 TEL • 86.21.3211.4580 FAX • CHINA.WATER@PENTAIR.COM EMAIL

EVERPURE-SHURFLO INDIA, GREEN BOULEVARD, B-9/A, 7TH FLOOR - TOWER B SECTOR 62, NOIDA - 201301
91.120.419.9444 TEL • 91.120.419.9400 FAX • INDIACUSTOMER@PENTAIR.COM EMAIL

EVERPURE-SHURFLO EUROPE, PENTAIR WATER BELGIUM BVBA, INDUSTRIEPARK WOLFSTEE, TOEKOMSTLAAN, 30 B-2200 HERENTALS, BELGIUM
+32.(0).14.283.500 TEL • +32.(0).14.283.505 FAX • SALES@EVERPURE-EUROPE.COM EMAIL

EVERPURE-SHURFLO JAPAN INC., HASHIMOTO MN BLDG. 7F, 3-25-1 HASHIMOTO, MIDORI-KU, SAGAMIHARA-SHI KANAGAWA 252-0143, JAPAN
81.(0)42.775.3011 TEL • 81.(0)42.775.3015 FAX • INFO@EVERPURE.CO.JP EMAIL

EVERPURE-SHURFLO SOUTHEAST ASIA, 390 HAVELOCK ROAD, #04-01, KING'S CENTRE, SINGAPORE 169662
65.6795.2213 TEL • FAX: 65.6795.2219 FAX • CSEVERPURE@PENTAIR.COM EMAIL

All Pentair trademarks and logos are owned by Pentair, Inc. All other brand or product names are trademarks or registered marks of their respective owners. Because we are continuously improving our products and services, Pentair reserves the right to change specifications without prior notice. Pentair is an equal opportunity employer.



EVERPURE® i2000² FILTER CARTRIDGE

DELIVERS PREMIUM QUALITY WATER FOR ICE APPLICATIONS

i2000² Replacement Cartridge: EV9612-22



APPLICATIONS

Ice

FEATURES • BENEFITS

Proprietary Micro-Pure® II filtration media effectively inhibits the growth of bacteria on the filter media that can decrease product life

Sanitary cartridge replacement is simple, quick and clean. Internal filter parts are never exposed to handling or contamination

Reduces water-related ice machine problems caused by scale buildup from dirt and dissolved minerals*

Self-contained scale inhibitor feed keeps ice machines functioning at full capacity*

Reduces maintenance and service costs by reducing scale and clogging of distribution lines, evaporator plate and pump*

Exclusive precoat filtration provides superior chlorine taste and odor reduction and micro-filters dirt and particles as small as 0.5 micron in size by mechanical means.

NSF/ANSI Standard 53 certified to reduce cysts such as *Cryptosporidium* and *Giardia* by mechanical means

INSTALLATION TIPS

Install vertically with cartridge hanging down

Allow 2-1/2" (6.35 cm) clearance below the cartridge for easy cartridge replacement

Flush cartridge by running water through filter for five (5) minutes at full flow

OPERATION TIPS

Change cartridges on a regular six (6) month preventative maintenance program

Change cartridges when capacity is reached or when pressure falls below 10 psi (0.7 bar)

Always flush the filter cartridge at time of installation and cartridge change

SIZING

Service Flow Rate: Maximum 1.67 gpm (6.3 Lpm)

Capacity: 9,000 gallons (34,069 L)

*As tested by Everpure

EVERPURE® i2000 FILTER CARTRIDGE

EV9612-22

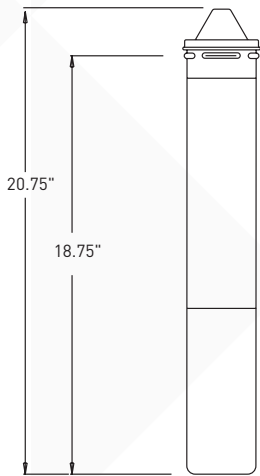

SPECIFICATIONS

Overall Dimensions

20.75" L x 3.25" dia. (52.7 x 8.2 cm)

Capacity

9,000 gallons (34,069 L)

Service Flow Rate

Maximum 1.67 gpm (6.3 Lpm)

Pressure Requirements

10 - 125 psi (0.7 - 8.6 bar), non-shock

Temperature

35 - 100°F (2 - 38°C)

Electrical Connection

None required



System Tested and Certified by NSF International against NSF/ANSI Standard 42 and 53 for the reduction of:

Standard No. 42: Aesthetic Effects
Chemical Unit
Taste and Odor Reduction
Chlorine Reduction
Mechanical Filtration Unit
Nominal Particulate Reduction, Class I

Standard No. 53: Health Effects
Mechanical Filtration Unit
Turbidity Reduction
Cyst Reduction
Asbestos Reduction

EPA No. 002623-IL-002

The contaminants or other substances removed or reduced by this drinking water system are not necessarily in your water. Do not use with water that is microbiologically unsafe or of unknown quality without adequate disinfection before or after the system. Systems certified for cyst reduction may be used with disinfected water that may contain filterable cysts.

WARRANTY

Everpure water treatment systems by Pentair® (excluding replaceable elements) are covered by a limited warranty against defects in material and workmanship for a period of five years after date of purchase. Everpure replaceable elements (filter cartridges and water treatment cartridges) are covered by a limited warranty against defects in material and workmanship for a period of one year after date of purchase. See printed warranty for details. Pentair will provide a copy of the warranty upon request.



FILTRATION & PROCESSING SOLUTIONS

EVERPURE-SHURFLO WORLD HEADQUARTERS, 1040 MUIRFIELD DRIVE, HANOVER PARK, IL 60133 USA • WWW.EVERPURE.COM
800.942.1153 MAIN (US ONLY) • 630.307.3000 MAIN • 630.307.3030 FAX • CSEVERPURE@PENTAIR.COM EMAIL

EVERPURE-SHURFLO AUSTRALIA / NEW ZEALAND, 1-21 MONASH DRIVE, DANDENONG SOUTH, VIC, 3175, AUSTRALIA
1300.576.190 TEL • AU.EVERPURE@PENTAIR.COM EMAIL

EVERPURE-SHURFLO CHINA, 21F CLOUD 9 PLAZA, NO 1118, SHANGHAI, 200052, CHINA
86.21.3211.4588 TEL • 86.21.3211.4580 FAX • CHINA.WATER@PENTAIR.COM EMAIL

EVERPURE-SHURFLO INDIA, GREEN BOULEVARD, B-9/A, 7TH FLOOR - TOWER B SECTOR 62, NOIDA - 201301
91.120.419.9444 TEL • 91.120.419.9400 FAX • INDIACUSTOMER@PENTAIR.COM EMAIL

EVERPURE-SHURFLO EUROPE, PENTAIR WATER BELGIUM BVBA, INDUSTRIEPARK WOLFSTEE, TOEKOMSTLAAN, 30 B-2200 HERENTALS, BELGIUM
+32.(0).14.283.500 TEL • +32.(0).14.283.505 FAX • SALES@EVERPURE-EUROPE.COM EMAIL

EVERPURE-SHURFLO JAPAN INC., HASHIMOTO MN BLDG. 7F, 3-25-1 HASHIMOTO, MIDORI-KU, SAGAMIHARA-SHI KANAGAWA 252-0143, JAPAN
81.(0)42.775.3011 TEL • 81.(0)42.775.3015 FAX • INFO@EVERPURE.CO.JP EMAIL

EVERPURE-SHURFLO SOUTHEAST ASIA, 390 HAVELOCK ROAD, #04-01, KING'S CENTRE, SINGAPORE 169662
65.6795.2213 TEL • FAX: 65.6795.2219 FAX • CSEVERPURE@PENTAIR.COM EMAIL

All Pentair trademarks and logos are owned by Pentair, Inc. All other brand or product names are trademarks or registered marks of their respective owners. Because we are continuously improving our products and services, Pentair reserves the right to change specifications without prior notice. Pentair is an equal opportunity employer.