

## Connectionless Steamer Powered by Microwave Technology

### NE-2180

*This Commercial Microwave Oven by Panasonic is ideal for heavy volume steaming and microwave applications in restaurants, banquets, supermarkets, delicatessens, school food service, health care and institutional catering.*

- 2100\* Watts of Cooking Power
- Large Oven Capacity: 1.6 Feet
- Door Opens Down to Hold Pans
- Top and Bottom Energy Feed
- Holds two 4" Tall, Full-size Steam Table Pans with Covers**

**SONIC  
STEAMER®**



**Panasonic ideas for life**



# NE-2180 Connectionless Steamer Powered by Microwave Technology

## Additional Features:

- Stainless Steel Cabinet and Cavity
- 4 Magnetrons (Heating Sources)
- 8 Programmable Memory Pads
- 16 Memory Capability
- 5 Power Levels
- 3-Stage Cooking
- Program List/Cycle Counter
- Programmable or Dial Timer
- Easy to Clean Air Filters
- See-Through Oven Door
- Easy to Change Interior Oven Light
- Digital Display
- Self Diagnostics
- Shift Key (AM-PM)
- Removable Center Shelf
- Volume/Tone
- Chef Technical Support
- Will Ship via UPS
- NSF & UL Commercial Approved



**Top & Bottom  
Energy Feed**

Specifications	
NE-2180	
Power Source	208/230-240V, 60Hz Single Phase
Receptacle Required	30 Amp, NEMA 6-30R 
Frequency	2,450MHz
Required Power	208V (20.0A), 230-240V (18.0A)
Output	2100 Watts*
Outer Dimensions (wxdxh)	25 <sup>9</sup> / <sub>16</sub> " x 20 <sup>3</sup> / <sub>4</sub> " x 18 <sup>9</sup> / <sub>16</sub> "
Cavity Dimensions (wxdxh)	21 <sup>1</sup> / <sub>16</sub> " x 13" x 9 <sup>7</sup> / <sub>8</sub> "
Net Weight	117 lbs.
Shipping Weight	128 lbs.
Shipping Box Size (wxdxh)	29 <sup>7</sup> / <sub>8</sub> " x 26 <sup>1</sup> / <sub>8</sub> " x 22 <sup>1</sup> / <sub>4</sub> ", 9.9 cu. ft.
Timer	Maximum Times for Each Stage of Cooking – Hi & Med. Power=15 Min. – Low, Defrost & Hold=60 Min.
Memory Capability	16 Programs

## Stainless Steel Cabinet and Cavity

The stainless steel cabinet and cavity makes for easy cleaning.

## To Specify a Panasonic Commercial Microwave Oven

The NE-2180 Commercial Microwave Oven meets or exceeds all safety performance and sanitation standards set for commercial food service microwave ovens by UL, DHHS, FCC and NSF. Plus, oven shall have output power 2100 Watts\*, equipped with 4 magnetrons, top and bottom energy feed, door opens down to hold pans with Grab & Go door handle, removable center shelf, 8 programmable pads, 16 memories, shift key (AM-PM), 3-stage cooking, 5 power levels (HI, MED., LOW, DEF., HOLD), programmable lock, cycle counter, volume/tone, self diagnostics, dial timer to select cooking time, video training, Chef/Test Kitchen technical support and 3 years limited warranty. 1 year parts and labor. 3 years magnetron.

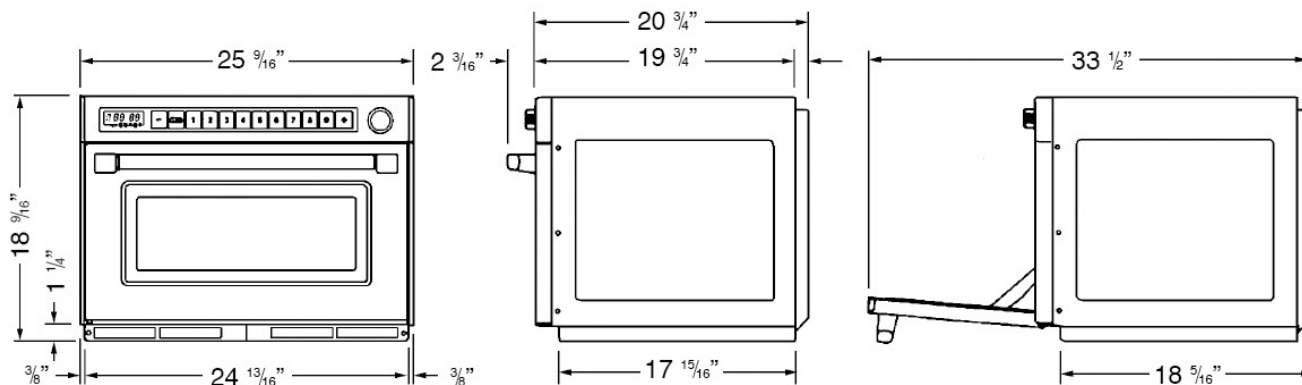

\* I.E.C. 60705-88 Test Procedure. Specifications subject to change without notice.

# Panasonic ideas for life

**Panasonic Home & Commercial Appliance Group**  
Panasonic Corporation of North America  
Executive Offices: One Panasonic Way, Panazip 1H-2  
Secaucus, NJ 07094

Toll-free: **877-CMO-OVEN (266-6836)**

Sales Support, Recipes and Training at: [www.panasonic.com/cmo](http://www.panasonic.com/cmo)

For a Panasonic Distributor/Services nearest you, 1-800-350-9590