



36" Six Burner Gas Range with a Standard Oven

Argus gas ranges are constructed of a stainless steel front, backriser, shelf and feet with galvanized sides. Each 30,000 BTU burner has its own 12"x12" removable cast iron grate with standing pilot light and individual control knob for quick, instant lighting. The standard oven has a total BTU output of 30,000 BTU/hr. The interior of the oven is constructed of all steel with a porcelain oven liner on the bottom. The oven thermostat adjusts from 250°F- 550°F and is equipped with a flame failure safety device. 3/4" rear NPT gas connection.



This item meets the sanitation standards imposed by the ETL, a division of the Intertek Group.



This item meets the electrical product safety standards imposed by the ETL, a division of the Intertek Group, for use in the United States and Canada.



HFSO-36

Plan Views

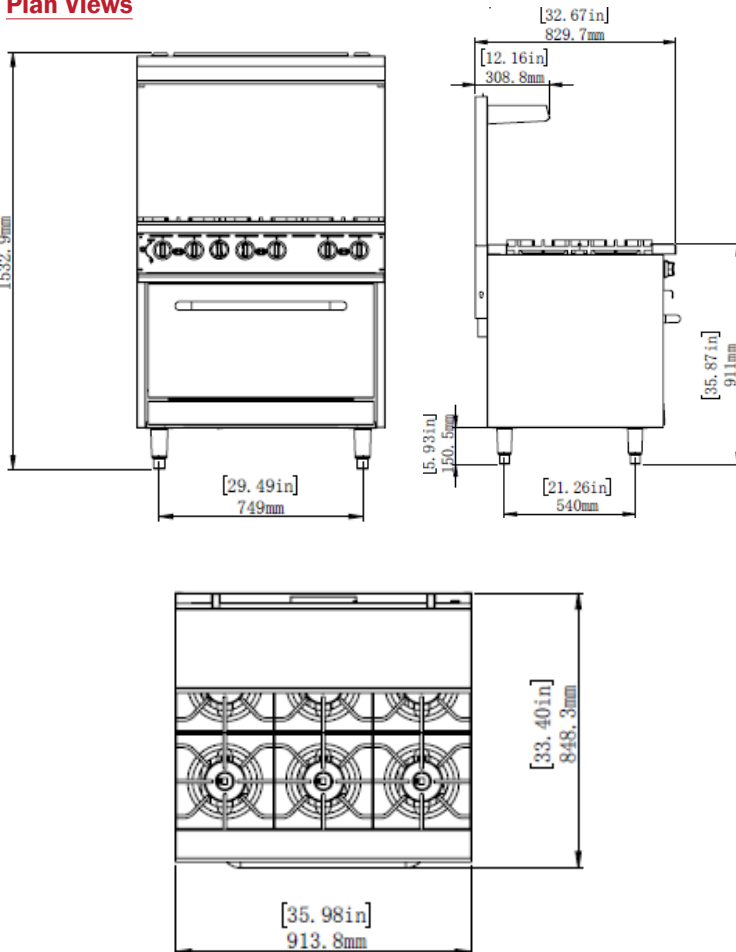

Features

- 210,000 BTU/hr total output
- Thermal coupling safety valve for the oven
- Cooling switch to reduce oven temperature quickly
- Includes 2 adjustable oven racks
- Cool to touch stainless steel oven door handle
- U shaped oven burner
- Individual pilot light for each burner
- Spring loaded door with cool to touch handle
- Removable crumb tray for easy cleaning
- Range ships with 6" adjustable eggs installed
- Ships Natural Gas with a LPG conversion kit included

Specifications

Model Number	HFSO-36
Total BTU/hr	210,000 BTU
Overall Dimensions (in)	36"W x 35"D x 56.5"H
Oven Cavity Dimensions	26.6"W x 23.5"D x 13.8"H
Temperature Range	250°F - 550°F
Net Weight (lbs)	368 lbs
Gross Weight (lbs)	456 lbs
Fit Full Size Pan	Yes
Crumb Tray	1
Burners	6