

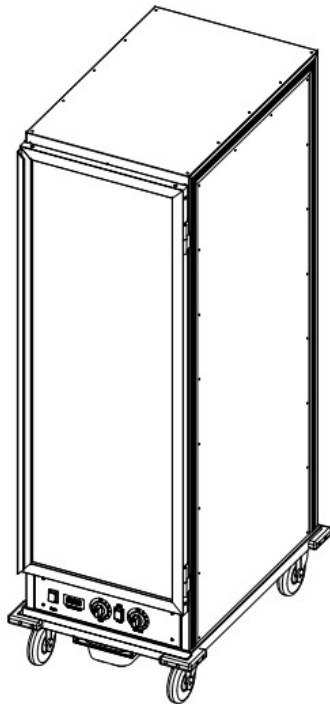

SENTINEL™

Heated Holding & Proofing Cabinets Installation & Operation Manual



Model # RHC1836HPA/RHC1836HPICUA2

Please read and keep these instructions.



Index

Important Safety Information.....	3
Identification of Key Parts.....	4
Electric Diagram.....	4
Specification.....	5
Installation Of Your Warming Cabinet.....	5
Using Your Warming Cabinet.....	6
Food Setting Guide.....	7
Cleaning & Maintaining Your Warming Cabinet.....	8
Troubleshooting.....	8
Exploded View.....	8-9

IMPORTANT SAFETY INFORMATION

When using electrical appliances basic safety precautions should always be followed, including the following:

1. Read all instructions carefully and completely.
2. For commercial use only.
3. Do not touch hot surfaces.
4. Protect against electrical shock by keeping all cords, plugs, and other electrical components away from water or other liquids.
5. Unplug this unit when not in use and before cleaning.
6. Allow the unit to cool before putting on or taking off parts.
7. Do not operate this or any appliance with a damaged electrical cord or plug.
8. Do not operate this or any appliance after it has malfunctioned or been damaged in any way.
9. Do not use outdoors.
10. Do not place on or near a hot gas or electric burner.
11. Attach plug to appliance first, then plug electrical cord into the wall outlet.
12. Disconnect the unit by turning the temperature and humidity control to "OFF", then removing the electrical plug from the wall outlet.
13. Do not use appliance for any application other than intended use.
14. Do not insert metal utensils or oversized foods into this unit as they may cause a fire and increase the risk of electrical shock.
15. Do not store any item on top of this unit when in operation.
16. Do not allow this warming cabinet to touch or be covered by flammable material, such as curtains, draperies, walls, etc., when in operation.
17. Do not clean with metal scouring pads as pieces can break off and touch electrical components, increasing the risk of electrical shock.
18. Never place materials such as paper, cardboard, plastic, etc. in this warming cabinet.
19. Do not cover interior of this unit with metal foil as it may cause the warming cabinet to overheat.
20. Avoid scratching the surface or nicking the edges of this unit's door. If the warming cabinet door has a scratch or nick, contact customer service before use.
21. Turn the appliance off by turning power switch to the "OFF" position.
22. This appliance is not intended for use by persons with reduced physical sensory or mental capabilities, or lack of experience and knowledge, unless they have been given supervision or instruction concerning use of the appliance by a person responsible for their safety.
23. When using the appliance for the first time check the voltage and outlet to make sure the appliance is correctly connected with power.
24. Place unit on a flat surface that is well ventilated. The appliances must be supervised during operation.

NOTE: Save these instructions for future reference.

Identification of Key Parts

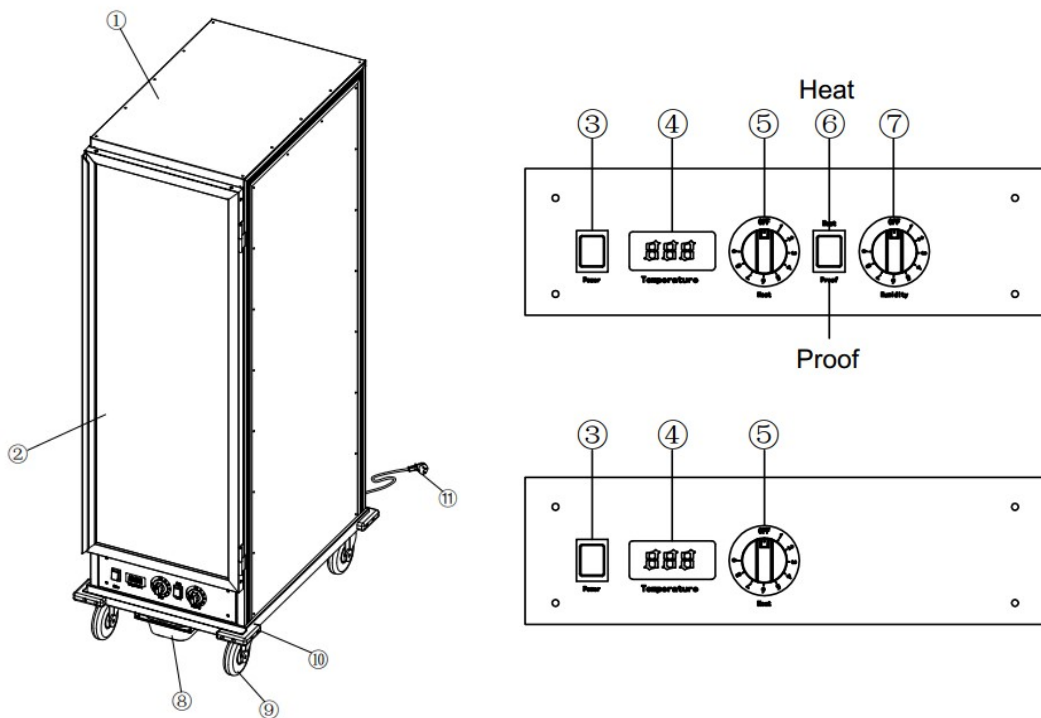

1. Main body 2. Door 3. Power switch 4. Temperature display 5. Temperature regulator 6. Heat & Proof switch 7. Humidity regulator 8. Water pan 9. Caster wheel 10. Corner guard 11. Power cord

Electric Diagram

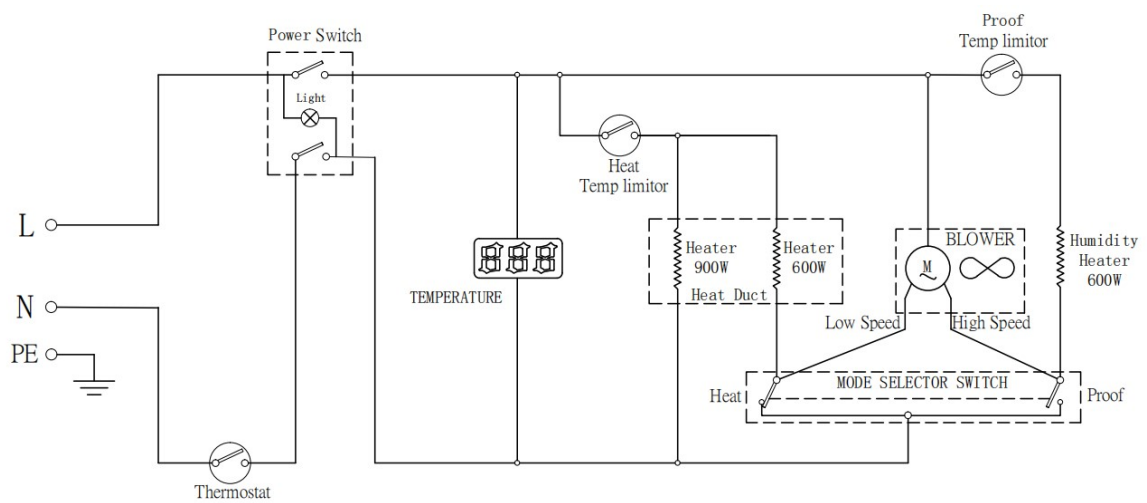

Specification

Model No.	Pan			Wattage	Overall	Shipping
	Capacity	Voltage	Hertz		Dims. (inches)	Dims. (inches)
RHC1836HPIA	36	120V	60 Hz	1500	23 x 33.5 x 68	25 x 37 x 75
RHC1836HPICUA2	34	120V	60 Hz	1500	23 x 33.5 x 68	25 x 37 x 75

Installation Of Your Warming Cabinet

All electrical connections must comply with the voltage, hertz and wattage shown in the chart above. The installation must be done by qualified personnel. It is highly recommended that you ONLY use the power cord supplied with the cabinet.

All models are free-standing, place the cabinet in a stable, level surface, and leave enough space (suggested 4" on all sides) for air ventilation.

Using Your Warming Cabinet

Basic cabinet setup

1. Plug the power cord to correct circuit-120V/60Hz/1500W.
2. Fill water pan to top with clean HOT tap water for Proofing or if moisture is desired for Holding. Check water level every 3 hours (2 hours when Proofing) and refill with clean HOT tap water as necessary. Water pan does not have to filled for Heating. Proofing requires water pan to be filled.

Heating instructions

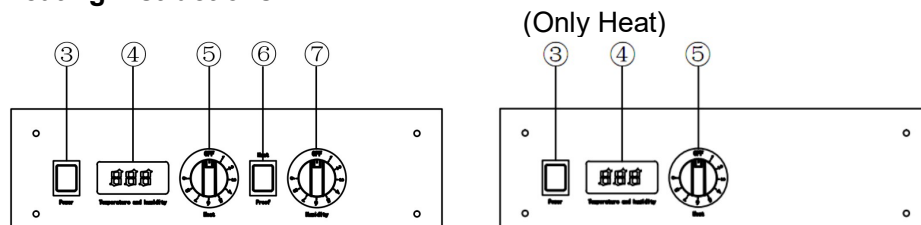

1. Set module switch to "Heat"
2. Set "Power" switch to "I" position, power indicator light turn on.
3. Set "Temperature" to "9".
4. Pre-heat cabinet until desired temperature is reached (usually heat- up time from 77°F(25°C) ambient to 160°F(71°C) is approximately 45 minutes).
5. Re-set "Temperature" control and adjust as necessary to reach desired temperature (setting 6-8 is typical for 150°F(66°C) to 160°F(71°C)).

Proofing instructions

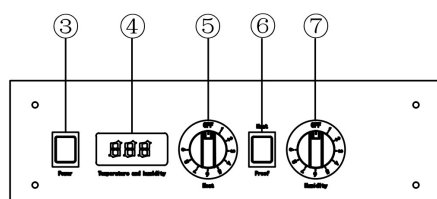

1. Set module switch to “**Proof**”.
2. Set “**Power**” switch to “**I**” position, power indicator light turn on.
3. Set “**Temperature**” control to “**2**”.
4. Set “**Humidity**” control to “**9**”.
5. Pre-heat cabinet until desired temperature and humidity is reached (usually heat-up time from 77°F(25°C) ambient to 95°F(35°C) and 95% relative humidity is approximately 30 minutes).
6. Adjust setting as necessary to reach desired temperature and humidity levels.

NOTE: The internal air circulation blower and heating element (are controlled with the Heat Thermostat) it will operate continuously when the power switch is turned “**I**” position.

Food Setting Guide

Breads		Starches	
Biscuit, Standard or Mini	175°F(79°C)	Fry, Regular 3/8”	195°F(91°C)
Croissants, Whole or Sliced	155°F(68°C)	Potatoes, Mashed	175°F(79°C)
French Toast, Thin Slice	175°F(79°C)	Potatoes, Baked	180°F(82°C)
Waffles, Original	175°F(79°C)	Potatoes, Scalloped	175°F(79°C)
Pancakes	175°F(79°C)	Pasta	180°F(82°C)
Pizza	175°F(79°C)	Rice	180°F(82°C)
Dough (Proofing)	90-100°F (32-38°C)	Lasagna, Meat Sauce & Cheese	185°F(85°C)
Rolls	175°F(79°C)	Beans	175°F(79°C)
Vegetables		Meats	
Broccoli, Spears	175°F(79°C)	Prime Rib	175°F(79°C)
Carrots, Sliced, Crinkled	175°F(79°C)	Hamburgers	180°F(82°C)
Cauliflower, Clusters	175°F(79°C)	Hot dogs	170°F(77°C)
Corn on the Cob	180°F(82°C)	Roast Beef	175°F(79°C)
Mixed Vegetables	175°F(79°C)	Roast Pork	175°F(79°C)
		Ribs (Pork Spareribs)	175°F(79°C)
Fish			
Fish, Baked	170°F(77°C)	Fish, Batter Dipped	175°F(79°C)
Poultry			
Chicken, Boneless, Skinless	175°F(79°C)	Chicken, Fried Thigh	175°F(79°C)
Chicken, Thigh, Baked, Fried	175°F(79°C)	Chicken, Fried Drum	175°F(79°C)
Chicken, Drum, Baked, Fried	175°F(79°C)	Chicken, Fried Boneless Skinless	175°F(79°C)
Chicken, Whole Roasted	170°F(77°C)	Chicken, Full Breast	175°F(79°C)
Chicken, Leg	175°F(79°C)	Turkey	175°F(79°C)
Chicken Fried Full Breast	175°F(79°C)		

NOTE:

1. Water pan must be in place during operation.
2. Unplug cabinet from wall and allow cabinet (and water) to cool before cleaning or servicing.
3. Do not spray or pour water on the module when cleaning and do not immerse the module in water. Wipe with a damp cloth and dry with a towel.
4. Keep cabinet and module clean. Accumulation of grease and other drippings could ignite.

Cleaning & Maintaining Your Warming Cabinet

To clean, first remove the power cord's plug from the wall outlet. Wait for the warming cabinet to cool. Use a damp cloth or sponge to gently wipe down the inside of the warming cabinet. Avoid soaking the inside of the warming cabinet or washing it in running water as this will cause serious damage to the unit.

Troubleshooting

Problem: The warming cabinet does not become hot after being switched on.

- Be sure that the power switch and module switch is set.
- Be sure that the temperature or humidity control knob is set.

Problem: There is a metallic sound when the warming cabinet is in use.

- Do not attempt to dismantle the warming cabinet.
- Contact your service agent right away to examine the fan.

Problem: Food is often overheated or burned, even when set according to the chart.

- Check that the fan motor is operating normally.
- Contact your service agent to examine the temperature control knob.

Exploded View

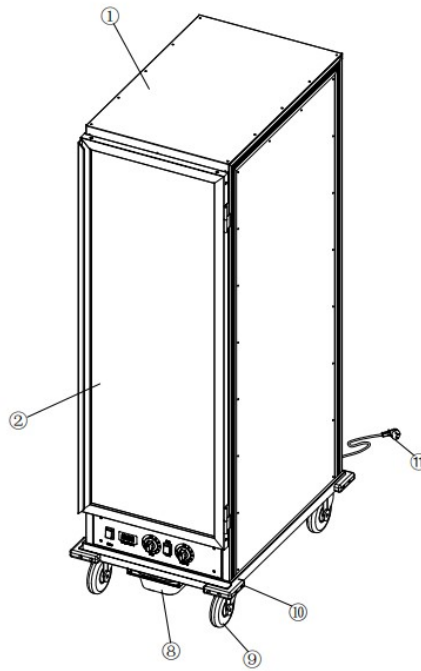

No.	Part Name	Quantity
1	Main body	1
2	Door assembly	1
8	Water Pan	1
9	Caster wheel	4
10	Corner Guard	4
11	Power cord	1

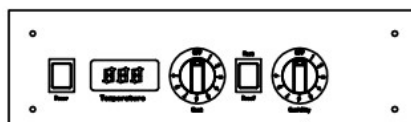
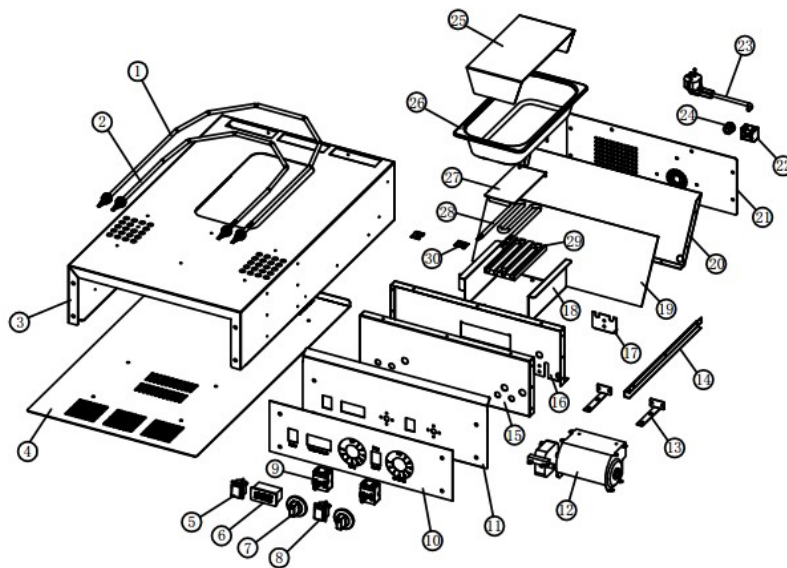

NO.	Part Name	Quantity
1	Heating element-2-120V/900W	1
2	Heating element-3-120V/600W	1
5	Power switch	1
6	Temperature display	1
7	Temperature control knob	2
8	Heat & Proof switch	1
9	Thermostat	2
12	Fan motor	1
22	Ceramic terminal	1
23	Power cord clip	1
24	Power cord	1
26	SUS GN pan	1
28	Heating element-1 120V/600W	1

NOTE:

- A. heating element-3 plus heating element-1 is for proofing**
- B. Heating element-3 plus heating element-2 is for warming**



One Year Limited Warranty

Sentinel warrants its equipment against defects in materials and workmanship, subject to the following conditions:

Sentinel is warranted for one year, effective from the date of purchase by the original owner. A copy of the original receipt or other proof of purchase is required to obtain warranty coverage. This warranty applies to the original owner only, and is not assignable.

Should any product fail to function in its intended manner under normal use within the limits defined in this warranty, at Sentinel's discretion, such product will be repaired, replaced with a refurbished unit, or replaced with a new unit by Sentinel, after defective unit has been inspected and defect has been confirmed. Sentinel does not assume any liability for extended delays in replacing any item beyond its control. This warranty does not apply to rubber and non-metallic synthetic parts that may need to be replaced due to normal usage, wear or lack of preventative maintenance.

This warranty covers products shipped into the 48 contiguous United States, Hawaii, and metropolitan areas of Alaska and Canada. Warranty coverage on products used outside the 48 contiguous United States, Hawaii and metropolitan areas of Alaska and Canada may vary.

The following conditions are not covered by warranty:

- Equipment failure relating to improper installation, improper utility connection or supply and problems due to improper ventilation.
- Equipment that has not properly been maintained, damage from improper cleaning, and water damage to controls.
- Equipment that has not been used in an appropriate manner, or has been subject to misuse, neglect, abuse, accident, alteration, negligence, damage during transit, delivery or installation, fire, flood, riot, or act of God.
- Equipment that has the model number or serial number removed or altered.
- Equipment on which the security seal has been broken.

If the equipment has been changed, altered, modified, or repaired without express written permission from Patriot, then the manufacturer shall not be liable for any damages to any person or to any property, which may result from the use of this equipment thereafter.

This equipment is intended for commercial use only and this warranty is void if equipment is used in other than a commercial application.

For warranty and service call 888-585-9440. Please have your model number, serial number and proof of purchase ready.

“THE FOREGOING WARRANTY IS IN LIEU OF ANY AND ALL WARRANTIES EXPRESSED OR IMPLIED INCLUDING ANY IMPLIED WARRANTY OF MERCHANTABILITY OR FITNESS FOR PARTICULAR PURPOSES AND CONSTITUTES THE ENTIRE LIABILITY OF ACE. IN NO EVENT DOES THE LIMITED WARRANTY EXTEND BEYOND THE TERMS STATED HEREIN.”
